



P-220 Series Plastic Valves

Installation Instructions

Introduction

Built on proven technologies and components, the Toro P-220 Series plastic valves are tough, have excellent performance and are extremely reliable.

A self-cleaning metering system and 220 PSI rating assures years of trouble-free performance.

In commercial installations, it is advantageous to install the valves in a valve box. This enables the valve to be easily located, accessed and maintained. The use of clean aggregate in the the bottom of the box, and locating the valve box away from structures, potential hardscaping features (such as sidewalks) and large planting locations is recommended. Additionally, valve box locations generally should be in shrub beds and at right angles to structure locations. If the valves are installed below grade without a valve box, access to the top of the valve should be provided by using a section of 4" PVC pipe and a Toro Valve Cover (P/N 850-00) installed directly over each valve.

Features:

- 220 PSI maximum pressure rating
- Removable, self-cleaning metering system
- Precise pressure control with compact EZReg dial design (pressure regulating models)
- Pressure regulated in electric and manual modes, serviceable under pressure
- Schrader-type valve for pressure gauge attachment
- Manual flow control: adjustable to zero flow
- Internal manual bleed screw: bleeds internally downstream
- External manual bleed screw: bleeds to atmosphere, allows cleaning of metering rod and provides maximum flushing

Specifications:

Models:

P-220 Series electric, and electric pressure regulating - 1", 1½", 2" and 3"

Body Style:

Globe/Angle with Female Threads (all models)
BSP Threads Available

Dimensions:

- 1" — 6¼" H x 3¾" W
- 1½" — 6½" H x 3⅝" W
- 2" — 9½" H x 6⅞" W
- 3" — 10¼" H x 6⅞" W

Flow range:

- 1" — 5-50 GPM
- 1½" — 30-110 GPM
- 2" — 80-180 GPM
- 3" — 150-300 GPM

Burst pressure safety rating: 750 PSI

Operating pressure:

- Electric models: 10-220 PSI maximum
- Pressure regulating models:
 - EZR-30 (5-30 PSI, ± 3 PSI)
 - EZR-100 (5-100 PSI, ± 3 PSI)

Minimum pressure differential (between inlet and outlet): 10 PSI

Solenoid (standard): 24 V a.c.

- Inrush: 0.40 amps, 11.50 VA
- Holding: 0.20 amps, 5.75 VA

Voltage Requirement (based on inlet pressure):

- 22.5 V a.c. @ 220 PSI
- 21.1 V a.c. @ 200 PSI
- 20.2 V a.c. @ 175 PSI
- 19.1 V a.c. @ 150 PSI
- 18.2 V a.c. @ 125 PSI
- 16.1 V a.c. @ 75 PSI
- 16.0 V a.c. @ 50 PSI

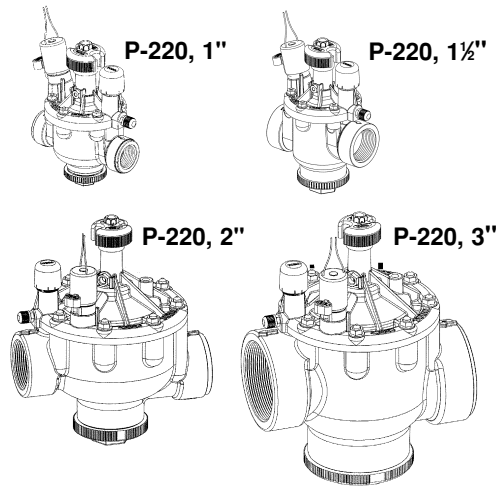

Friction Loss — U.S. (PSI)

GPM Flow

Size	Configuration	5	10	20	30	40	50	60	70	80	90	100	110	120	130	140	150	180	200	225	250	275	300	
1"	Globe	4.00	4.20	3.20	4.10	7.20	10.90																	
	Angle	4.00	4.20	3.10	2.70	4.80	7.90																	
1½"	Globe				1.60	2.30	3.60	5.20	7.00	9.20	11.70	14.40	17.50											
	Angle				1.30	1.60	2.80	4.00	5.50	7.10	9.00	11.00	13.30											
2"	Globe									2.10	2.70	3.30	4.00	4.80	5.60	6.50	7.50	8.05						
	Angle									1.20	1.60	2.00	2.40	2.80	3.30	3.90	4.40	5.10						
3"	Globe																2.50	3.00	4.10	5.30	6.70	8.30	10.10	
	Angle																1.90	2.40	3.30	4.30	5.50	6.90	8.50	

Notes: For optimum performance when designing a system, be sure to calculate total friction loss to ensure sufficient downstream pressure.
For optimum regulation performance, size regulating valves toward the higher flow ranges.

Installation Guidelines

CAUTION: Using pipe dope on valve connections can cause thread damage and failure of the valve body. Use only teflon tape or pipe thread sealant.

- Note the flow direction arrows on the bonnet or body and install accordingly
- The valve can be installed at any angle without affecting operation.
- The valve body plug and o-ring must be properly installed in the unused inlet.
- Use direct-burial wire, utilizing different color codes for each station control wire and one color for the common wire to all valves.
- Waterproof wire splice connectors are absolutely essential for proper electric control system operation. Follow the installation instructions provided with the connectors for optimum waterproof splice protection.
- Leaving a wire expansion loop at each valve location on long-run wire lengths is recommended.

Valve Operation and Adjustment

Flow Control

The flow control is used to reduce the flow and pressure to valve outlet. By turning the control handle clockwise, the flow will be gradually reduced to zero.

- For valve models **without** EZReg, adjust the flow control as necessary for optimum sprinkler performance.
- For valve models **with** EZReg, the flow control should remain in the fully open position. Use only for emergency shut off or for valve zone fine tuning.

Internal Manual Bleed Knob

The internal manual bleed system is used to manually operate the valve. Turning the internal bleed knob (located beneath the solenoid) counterclockwise allows water to bleed downstream from the diaphragm chamber. Internal pressure is relieved from the top of the diaphragm, allowing the valve to open. Turning the bleed knob clockwise until tight shuts off the discharge enabling pressure to build within the diaphragm chamber, causing the valve to close.

External Manual Bleed Knob (flush mode)

The external manual bleed knob, located on top of the flow control handle, is used for system flushing. Turning this knob counterclockwise allows water in the diaphragm chamber to vent to atmosphere, creating maximum opening power and debris flushing action. This operation bypasses the regulator (if installed) and opens the valve fully, regardless of regulator setting. In addition, the metering rod (attached to the external bleed knob) can be easily removed for cleaning as necessary.

EZReg Adjustment (pressure regulating models only)

An accurate, adjustable dial, coupled with a forward-flow valve design, allows the P-220 series valve with EZReg to regulate downstream water pressure with precision. It's easy and simple to use and requires only 10 PSI differential pressure to operate. The EZReg will operate during powered and manual valve operation using internal manual bleed.

To adjust the downstream pressure, remove the cover from the regulator dial, then turn the dial until the pointer is on the desired pressure of 5-30 PSI (EZR-30) or 5-100 PSI (EZR-100).

Note: Due to the micro-adjustment feature of the EZReg, the dial requires 10 revolutions for complete regulation range.

Operate the valve (electrically or manually). Check the flow control to confirm that it is in the fully open position. Adjust the regulator dial if necessary for optimum sprinkler operation.

To confirm the downstream pressure using a pressure gauge, remove the cap from the Schrader-type valve located directly below the EZReg. Attach a Toro pressure gauge (Model 995-51) to the Schrader-type valve for a direct reading. Adjust the EZReg dial as necessary for the desired pressure.

Note: The valve will remain watertight in the closed position if removal of the EZReg assembly is required.

